

A light green map of Japan is visible in the background, showing the four main islands: Hokkaido, Honshu, Shikoku, and Kyushu. The map is centered and occupies most of the slide's background.

Recovery, Collection and Management of Mercury Containing Waste in Japan -Fluorescent Lamp-

Masaki Takaoka

*Department of Environmental Engineering,
Kyoto University, JAPAN*

UNEP-DTIE-IETC

WEEE/E-waste Management Workshop on Take-Back System, Osaka, Japan, 13-15 July, 2011

Presentation outline

- **Introduction**
 - Mercury issue
- **Present status of mercury containing products**
- **Recovery, collection and management of fluorescent lamp**
 - Municipality
 - Business
 - Akari Ansin Service
- **Future perspective & Acknowledgement**

Mercury issues

- Mercury : a chemical element and widely used in products because of its unique characteristics and one of the global hazardous pollutants due to the anthropogenic mercury emission.
- A part of inorganic mercury in waters changes into organic mercury, which cause biological accumulation. Long term exposure, or exposure during developmental stages, to mercury can permanently damage the brain, kidneys and fetus.
- UNEP GC, at its 25th session, agreed to establish **INC** to prepare a global legally binding instrument on mercury from 2010 and complete it prior to its 27th



Source: Minamata disease municipal museum



to reduce risks from releases of mercury,
to find environmentally sound solutions for the management of waste containing mercury and mercury compounds

Mercury containing products

- Lamps: Fluorescent, Cold cathode, High Intensity Discharge (HID)
- Battery
- Pigment
- Measuring Device
- Switch
- Chemical reagent
- Preservative for vaccine (Thiomersal)

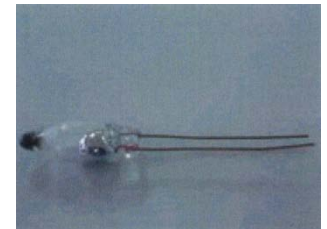
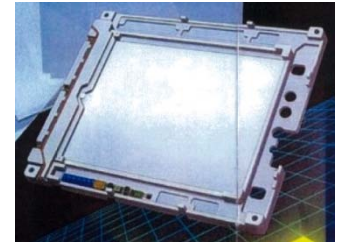
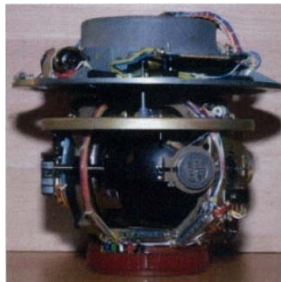

Trend of mercury demand in Japan

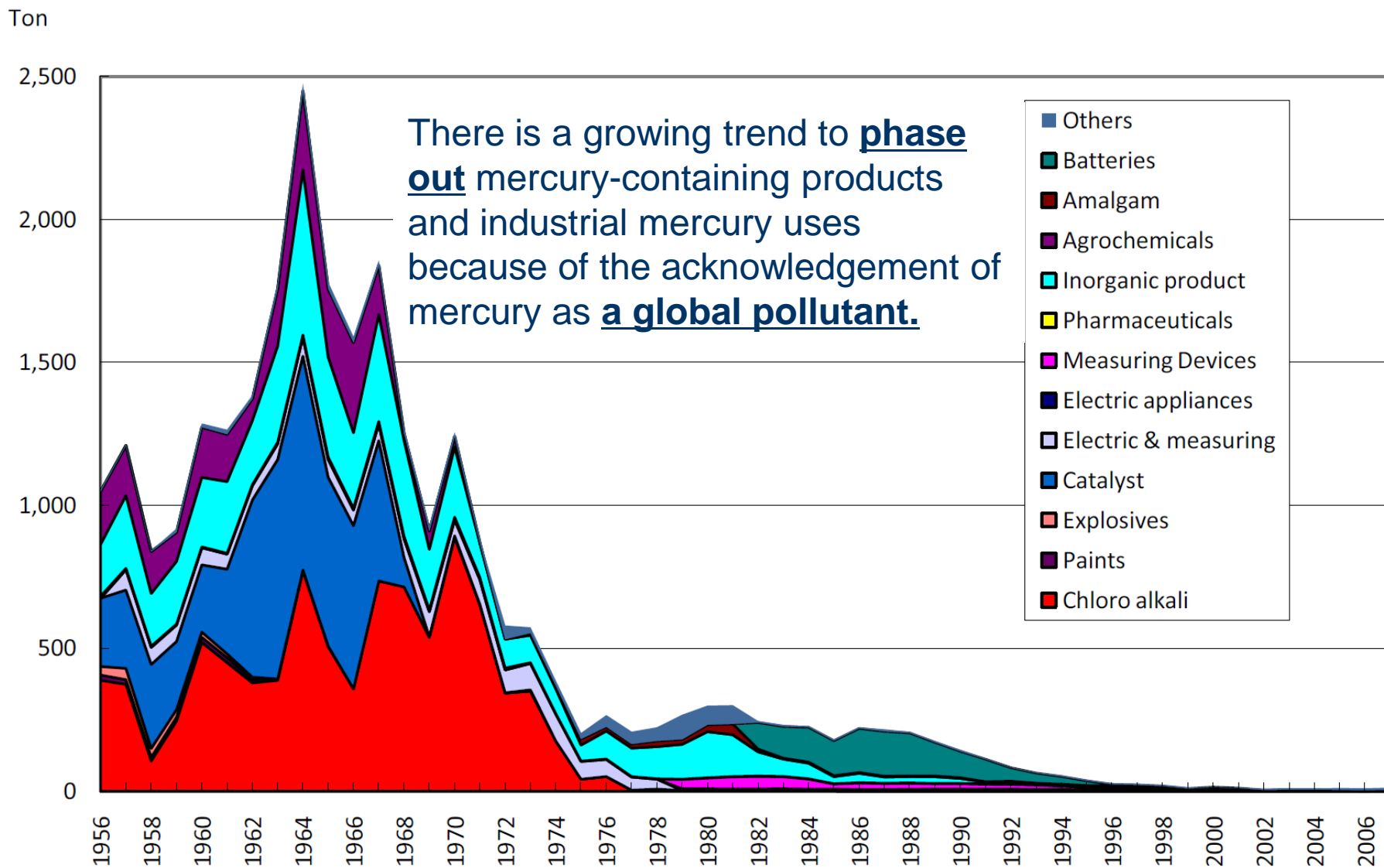

Fluorescent lamp

Fluorescent Tube Lamp

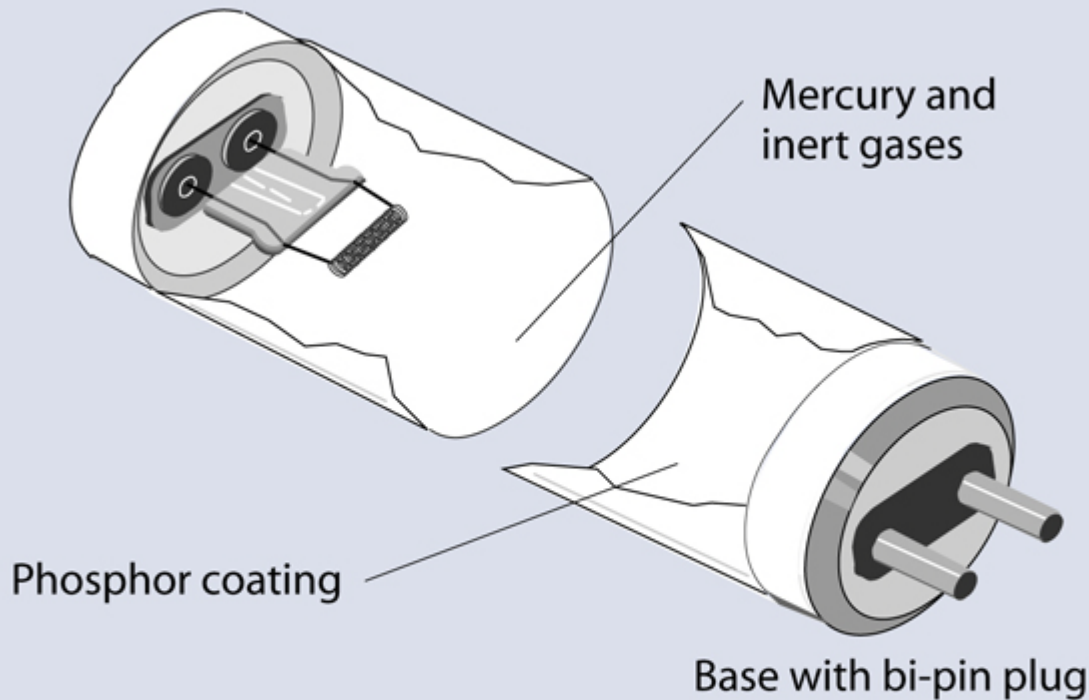

- When ionized, mercury vapor emits **ultraviolet light**.
- The phosphor accepts the energy of ultraviolet photons and emits visible photons.
- 50mg in 1974
- 7.5mg in 2007

In fluorescent tubes, a very small amount of mercury mixes with inert gases to conduct the electrical current. This allows the phosphor coating on the glass tube to emit light.

Source: USDOE

Output of fluorescent lamp

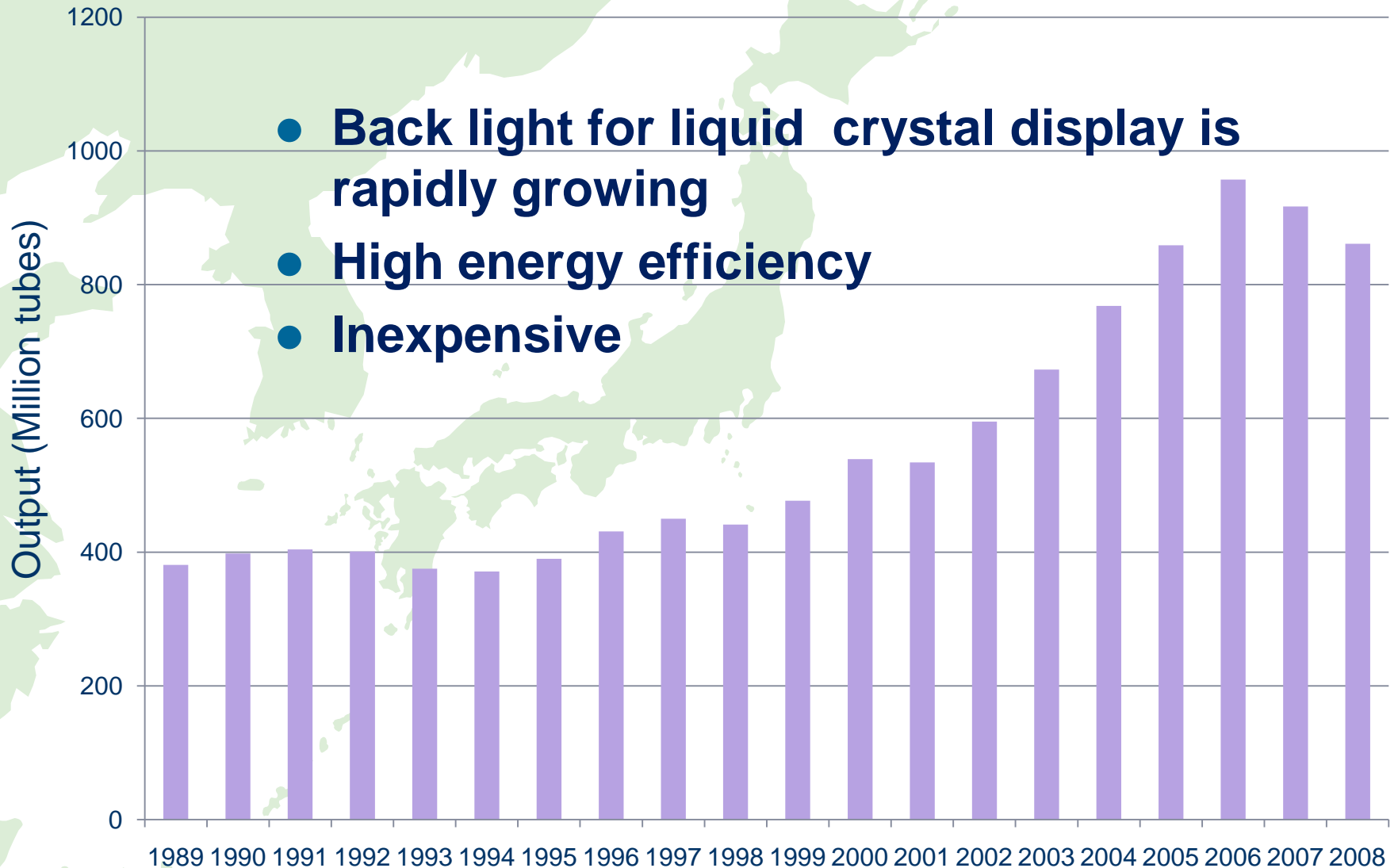

- **Back light for liquid crystal display is rapidly growing**
- **High energy efficiency**
- **Inexpensive**

Trend of mercury use in mercury containing lamp

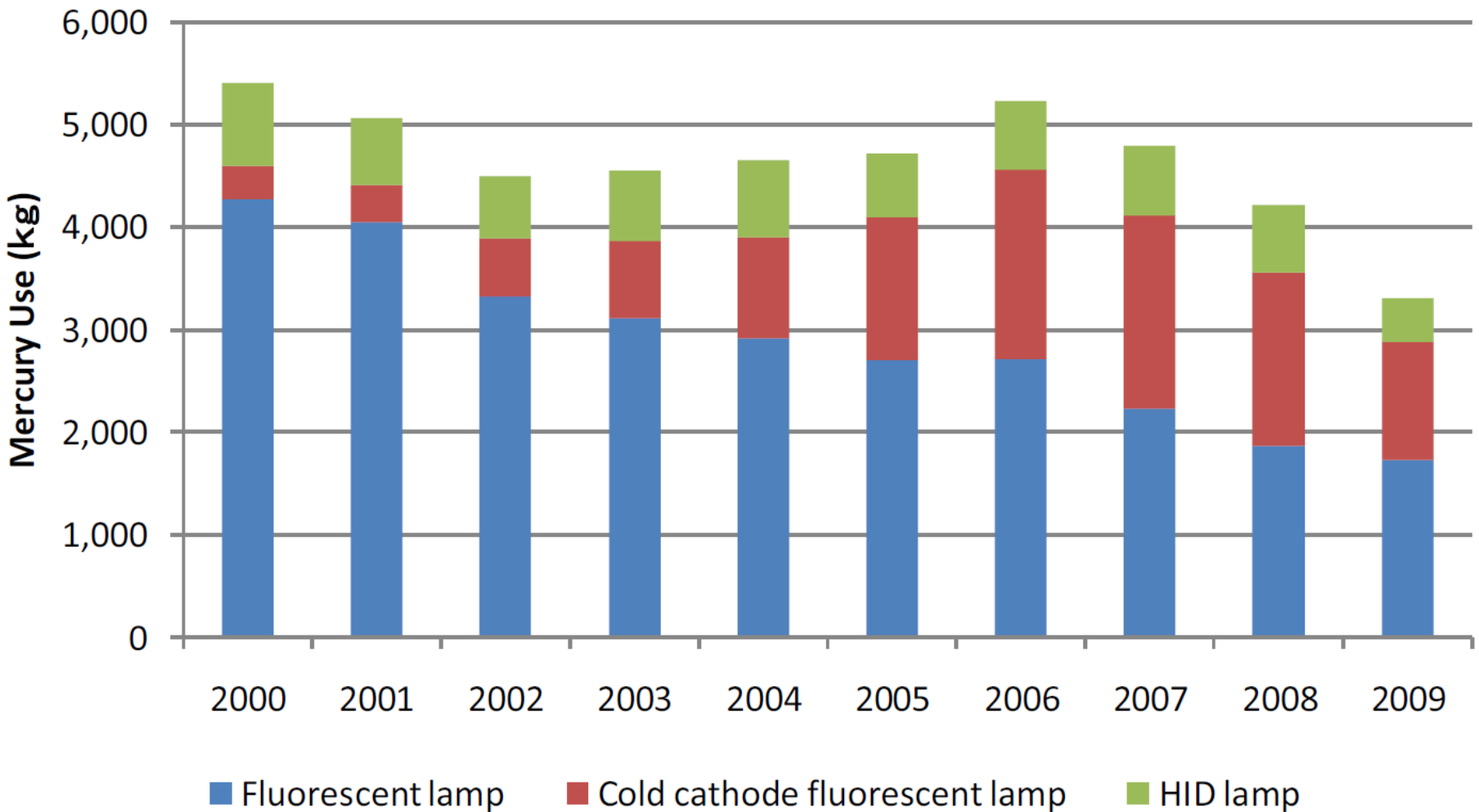

Collection from municipality

- In the face of the increasing social concern regarding **the emission of mercury from waste incinerators**, the Japan Waste Management Association prepared **the Wide Area Collection and Treatment Programme** for Used Dry Cells, etc. in 1986.
- **Used fluorescent lamps** were added in the scope of the Programme in FY 1999.

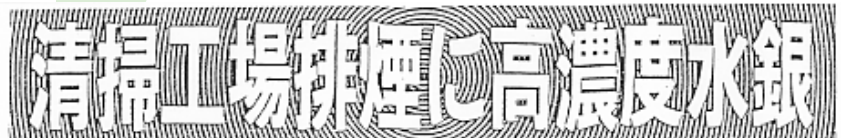

Source: Kusatsu city

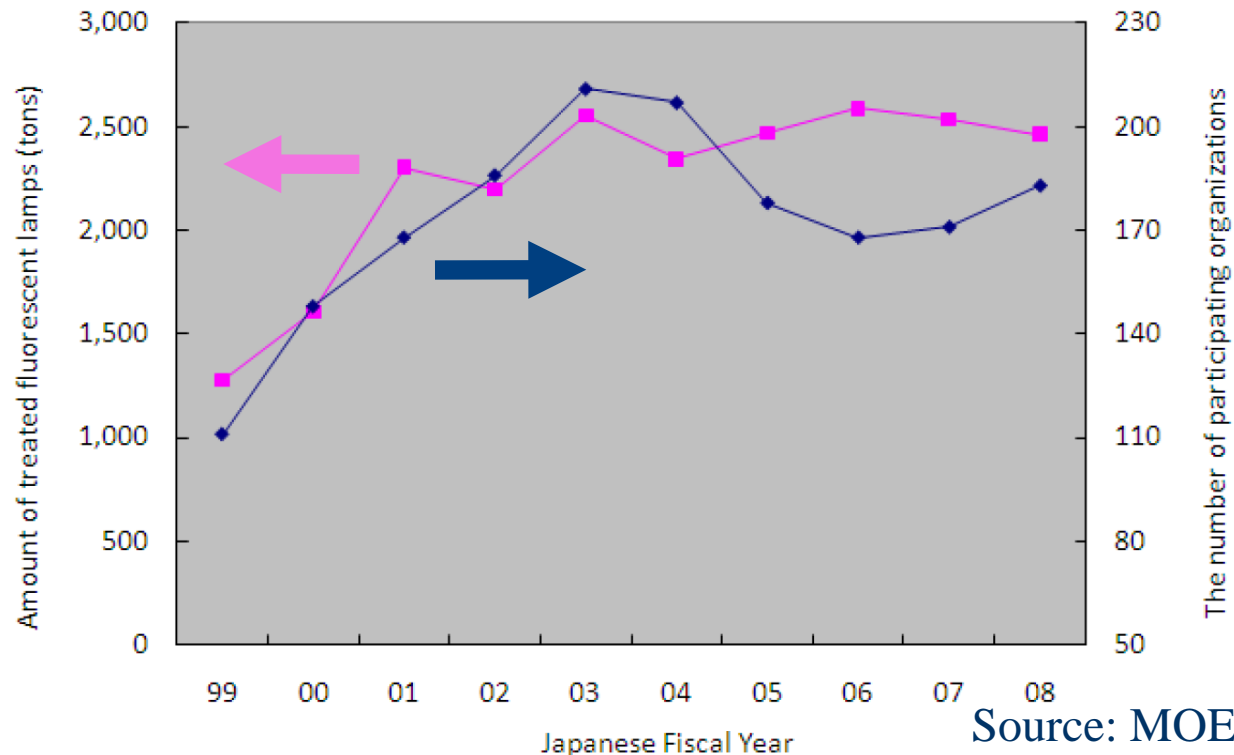

Source: MOE

Collection from business

- Manufacturers and others are engaged in the recycling and/or sale of resources recovered from home use liquid crystal(LC) televisions (pursuant to the Act on Recycling of Specified Types of Home Appliances) and notebook PCs and LC display units (pursuant to the Act on Promotion of Effective Utilisation of Resources). In the recycling process, the cold cathode fluorescent lamps for backlights are removed and handed over to a treater for the proper treatment and recovery of mercury.
- Many businesses recognize florescent lamps as hazardous waste and discharge them to a treater for the proper treatment and recovery of mercury.



Source: Um-
Welt JAPAN
home page



Kansai Recycle Systems co ltd. Source: Nikkei bp

More advanced system

● A leasing service for fluorescent lamps whereby fluorescent lamps are not "sold" but are leased by service agents designated by the manufacturers.

● Used fluorescent lamps are collected by the agents and are properly recycled via intermediate treaters while new replacement lamps are supplied to customers.

● This service is enjoyed not only by business establishments but also by plants, theme parks and other premises.

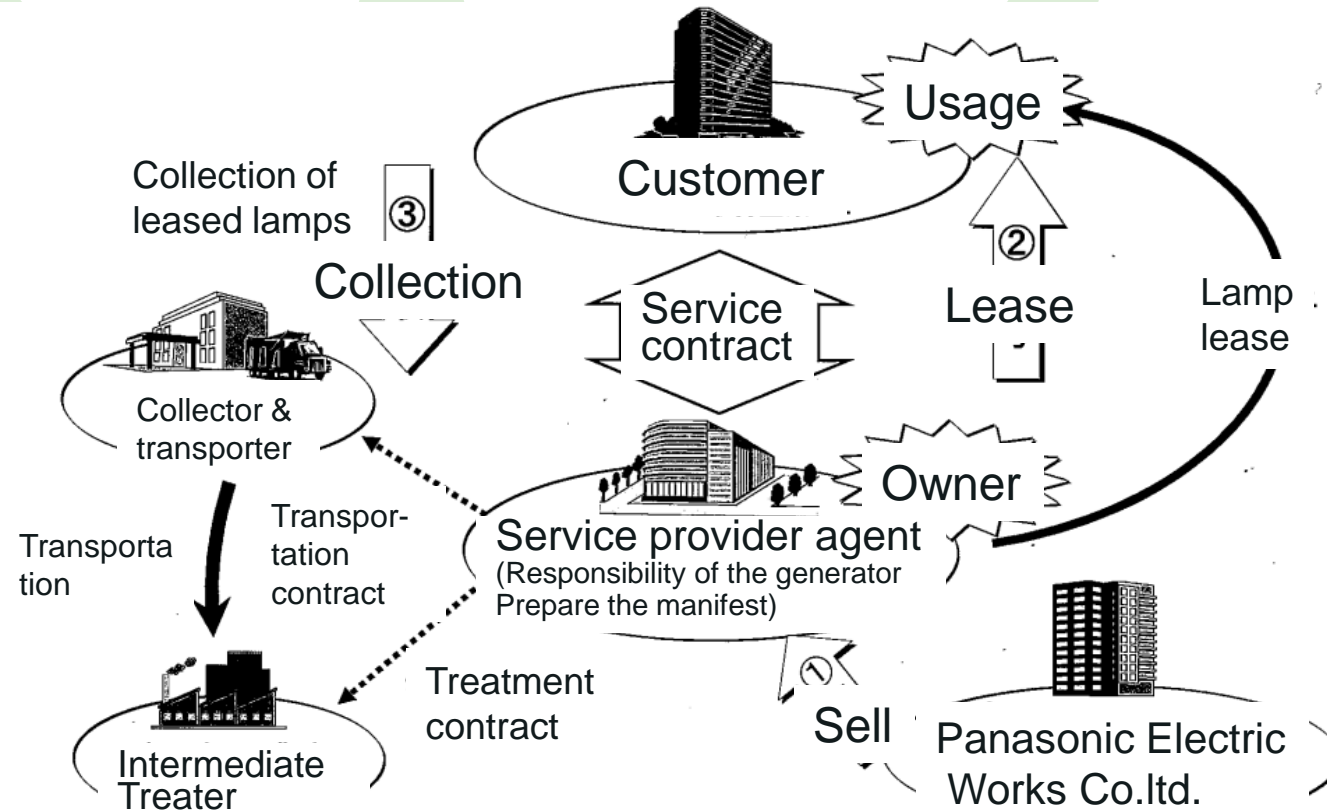

Advantages of this system

- As the fluorescent lamps of this service are owned by the service agent, customers can enjoy the advantage of not being required to produce a manifest based on the principle of discharging responsibility.
- There is also a tracking system via the Internet where participants can check the treatment progress of collected used fluorescent lamps.
- This system has been developed to guarantee the environmentally sound treatment and recycling of used fluorescent lamps.

Akari Ansin Service

- This service was started by **Panasonic Electric Works Co., Ltd** in April 2002.
- At present (February 2010) about **6800** facilities (factories, offices, theme parks etc) belonging to about **1200** businesses are using this service.
- It is estimated (based on assumption that 250,000 of 40W lamps are being used) that the amount of mercury collected amounts to about **18kg**.

Fluorescent lamp recycle

● The target used fluorescent lamps of this service are collected in their original form. The fluorescent powder, caps and mercury of fluorescent lamps are recycled to cover soil, aluminium and inorganic chemicals respectively. The glass is commonly recycled to produce **glass wool, light weight aggregate, tiles** and others.

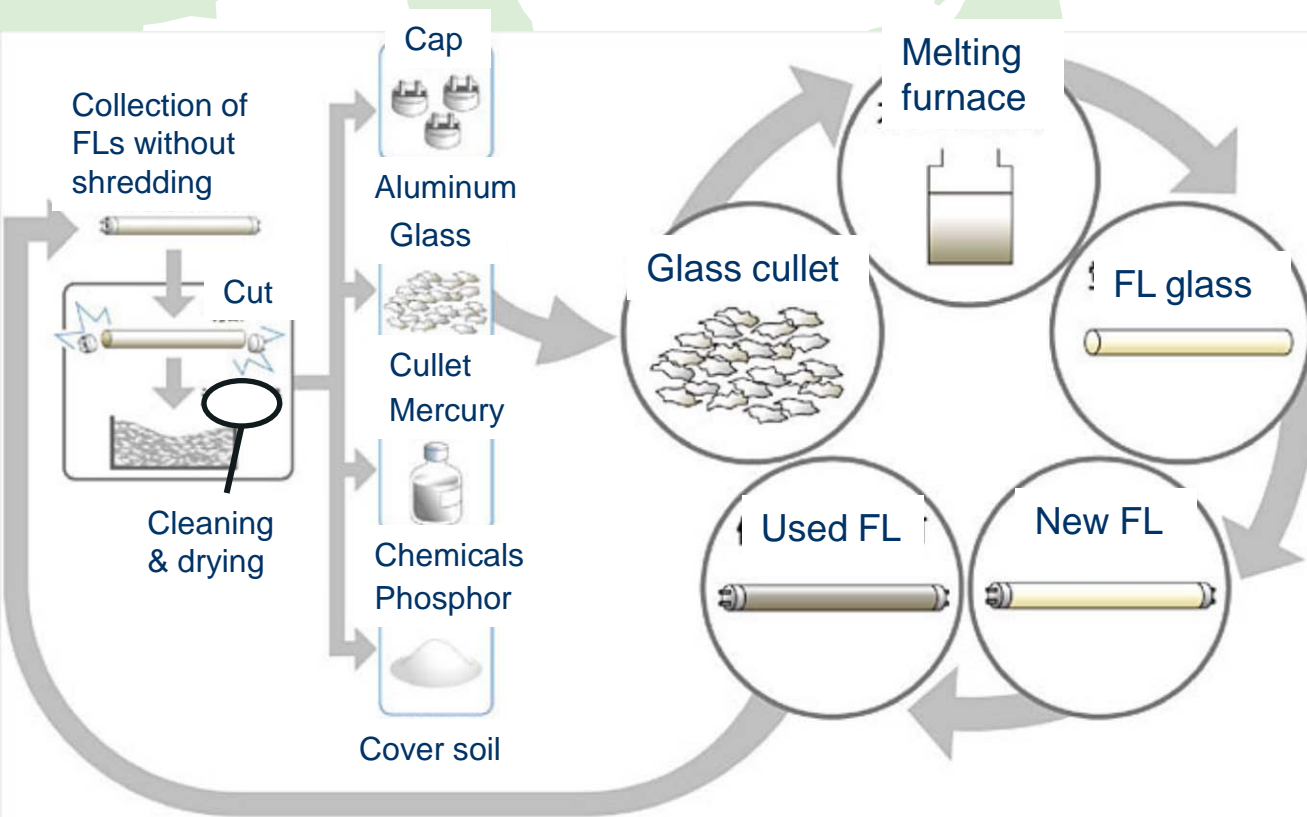

● Some fluorescent lamp manufacturers use the **recycled glass** to produce glass for **fluorescent lamps**, thereby achieving a recycling path from fluorescent lamps to fluorescent lamps.

Future perspective

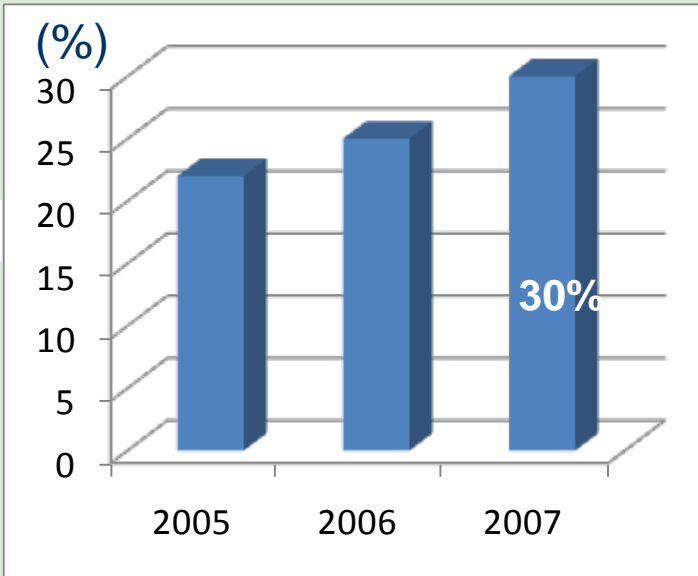

According to Dr. Asari (2011),

$$\text{Total recycling ratio} = \frac{\text{amount treated by recycler}}{\text{domestic production} - \text{export} + \text{import}}$$

- Production for business : 29639ton = production for home : 29815ton
- Recovered mercury : 356-928kg-Hg/year

Collection of FLs in municipalities

Separated	12
Hazardous	8
Incombustible	32
Combustible	1
Resource	1
Not collected	1
Total	55

● To increase collection rates,

- Promotion of separate collection in municipalities
- Collection at electronics retail store or do-it-yourself store
- Introduction of deposit system

Source: Takaoka et al. 2011

Acknowledgment

- We greatly thank the financial support by a Grand-in-Aid for Waste treatment Research from Ministry of the Environment, Japan in FY 2008-2010.
- **Basel Convention**
 - Technical Guidelines for the Environmentally Sound Management of Waste consisting of Elemental Mercury and Wastes Containing or Contaminated with Mercury
- **Waste Management Partnership Area in the UNEP**
 - Good Practices for Management of Mercury Releases from Waste

Thank you for your kind attention!